

# InstruPack

Instrumentation & Electrical Equipment Supports Manufacturer

InstruPack's Instruments Mounting Supports

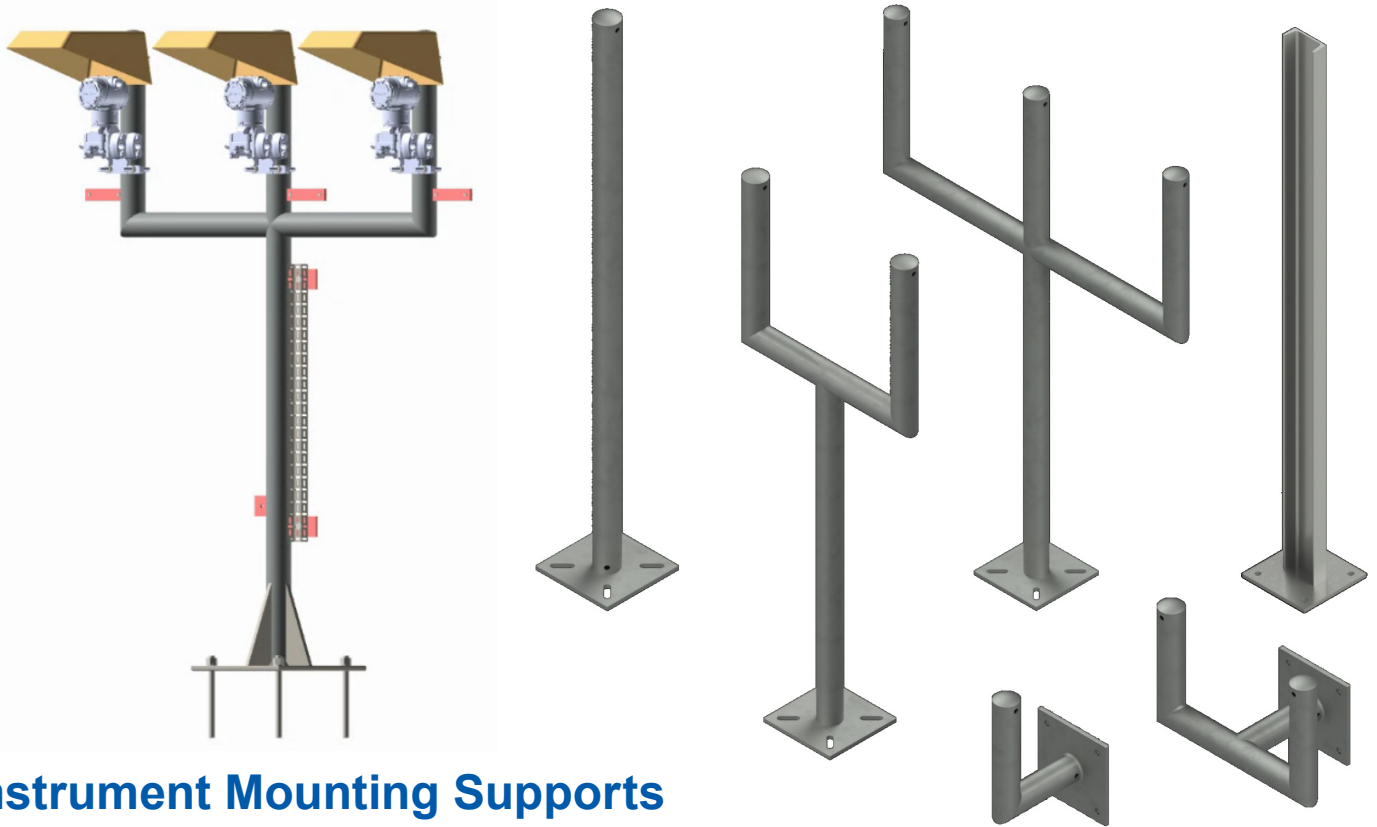

## Instrument Mounting Supports

- Singles, Doubles, Triples, Channel Stands
- Wall Mount, Floor Mount, Direct Burial, Pipe/Cable Mount
- Hot Dipped Galvanized, Stainless Steel, Painted

## Accessories

- Anchor Fasteners, Sunshades, U clamps
- Nuts / bolts, Instrument / Equipment Tag plates
- Earthing cords, Grating clamps,
- Beam Mount Bracket

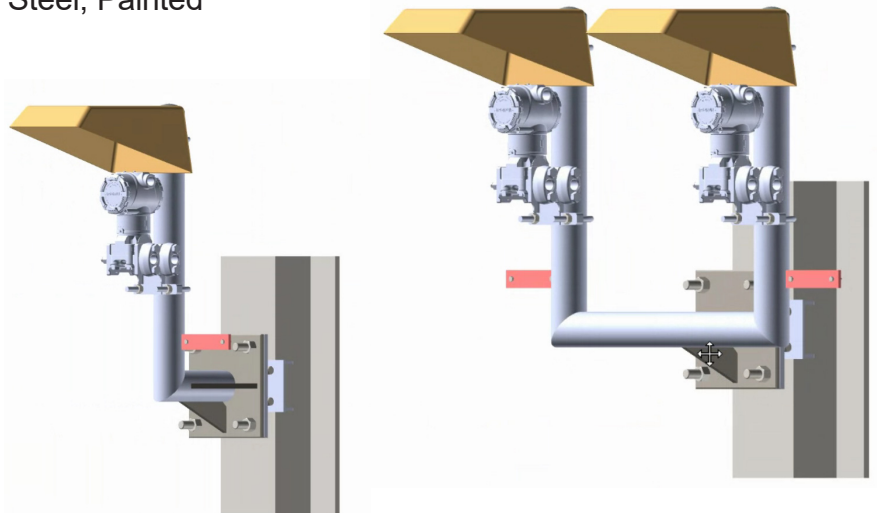

# InstruPack

## InstruPack

Instrumentation & Electrical Equipment Supports Manufacturer

Office Address: SF-26, Divya Plaza, Opp, Kamalanagar Lake Ajwa Road,  
Vadodara, Gujarat, India- 390019

Contact Details: +91 9725078592

Email: Rptechnsolution@outlook.com, instrupack@outlook.com

[www.InstruPack.com](http://www.InstruPack.com)

# InstruPack

## Instrumentation & Electrical Equipment Supports Manufacturer

InstruPack's Instrumentation and Electrical Equipment prefabricated Supports provide a proven and integrated solution with great advantages over site-fabricated supports.

InstruPack supports are provided in various designs, configurations suitable for all types of process instruments, manifolds, transmitters, solenoid valves, general field instrumentation, remote chemical sealed instruments, Local control stations, Fire and gas equipments, Outdoor Push buttons, CCTV etc.

### Benefits of InstruPack Supports



#### Easier Installation and Increased Customizability

- Typical designed for quick and straightforward installation
- Faster assembly and reducing downtime during installation



#### Standardization

- Simplify procurement, installation, and maintenance processes.
- Interchangeability between different types of Instruments and components Installation



#### Engineered Packaging

- Stands with all accessories are in one box/pallet reducing the site material handling, shortage and effectively reducing the idle manhours at a construction site
- Area Wise Packing reduces the material handling at site
- Integrated supply chain to support site construction schedule

### Instrument Stand Types

- Single Floor Stand
- Double and Triple Floor Stand
- Triple and Quad MultiRack Floor Stand
- Wall mount- Single and Double Stand
- Channel Floor Stand
- U-Bolt Mounts
- Cable Mounts
- Pipe Mount Stands

### Accessories

- Anchor Fasteners
- Sunshades
- U clamps
- Nuts / bolts, Instrument / Equipment Tag plates
- Earthing cords, Grating clamps
- Beam Mount Bracket



#### Cost-Effectiveness

- Reduce engineering and design time.
- Cataloged components eliminate design details.
- Minimize Material Wastage
- Minimize workers for Installation.
- Effectively reduce the ideal manhours at the construction site
- Reduce Skilled workers requirement at remote construction site



#### Enhanced Safety

- Minimize Site fabrication effectively reduce Lost Time Injury (LTI)
- Minimize Hot work requirements.



#### Improved Quality Assurance

- Produced in ISO 9001 facility.
- Raw material procurement as per end user specification and AVL
- Hot dip galvanizing, painting, and coating as per Instrupack standards or as per end user specification
- Excellent Corrosion Resistance

### Materials and Finishes

- Hot-dipped Galvanized
- 304SS
- 316SS
- Painted
- Powder Coated

### Applications of InstruPack's Supports

- Installation of Pressure, Flow, Level and Temperature Transmitters
- Installation of Local control stations, Remote seal Instruments, Push Buttons, Solenoid valves

